

# BMW

Sharp Innovators

PORTA-ATTREZZI  
FRUTTETO

serie  
FP850

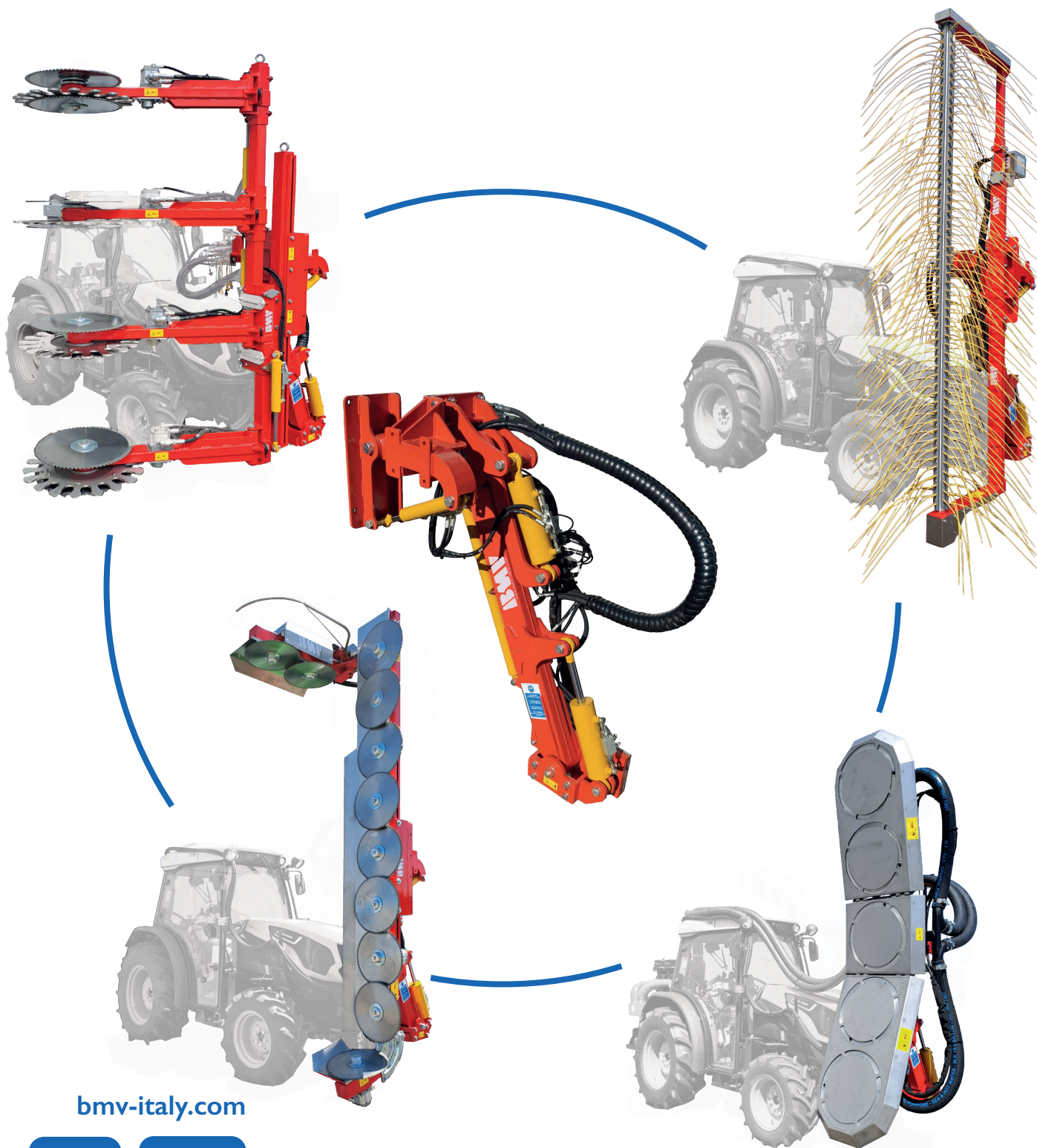

[bmw-italy.com](http://bmw-italy.com)

## BF200

GRUPPO TAGLIO PER STATURA (3 versioni di top disponibili)

1) TASTATORE AUTOMATICO ELETTRONICO abbinato a consolle joystick + display. Dal display è possibile regolare:

- FORZA MOLLA
- PISTONE TOP
- VELOCITA' RITORNO

2) TASTATORE MECCANICO a molla con pistone idraulico 0-90°

2) TOP 0-90° con pistone idraulico

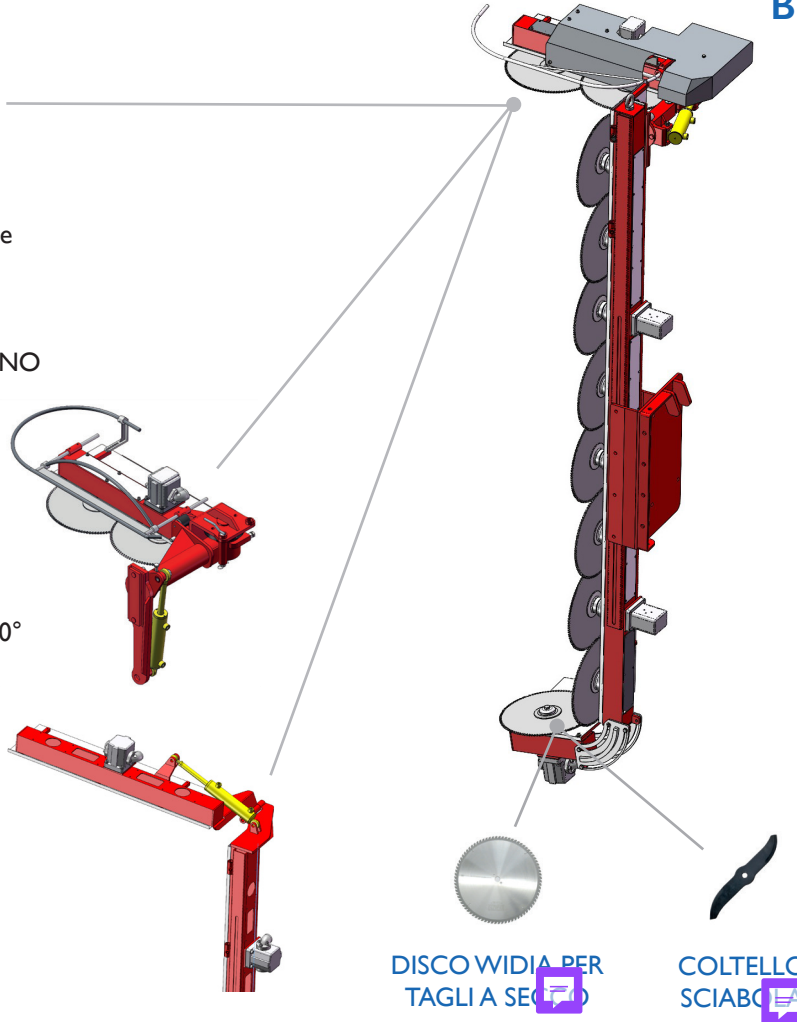

DISCO WIDIA PER TAGLI A SECCO

COLTELLO SCIABO

## WF300

## WF400

GRUPPO POTATRICE SELETTIVA A BRACCI

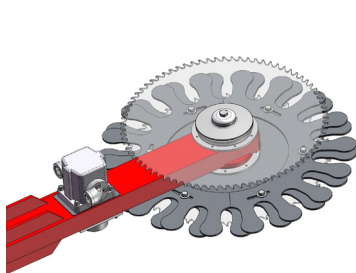

REGOLAZIONE DEL DIAMETRO DI TAGLIO IN BASE ALLA VEGETAZIONE

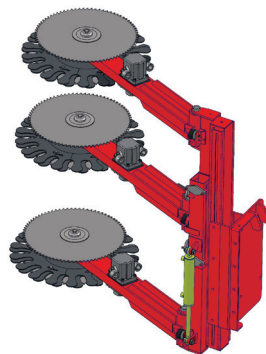

3 BRACCI

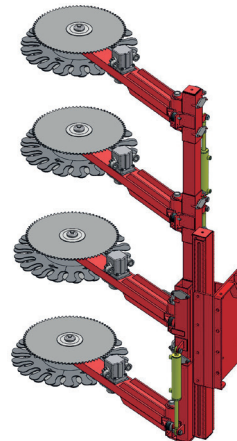

4 BRACCI

# PORTA-ATTREZZI serie **FP850**

## FP850

PIANTONE PORTA-ATTREZZI:

- N.3 movimenti idraulici
- Peso= 230 Kg

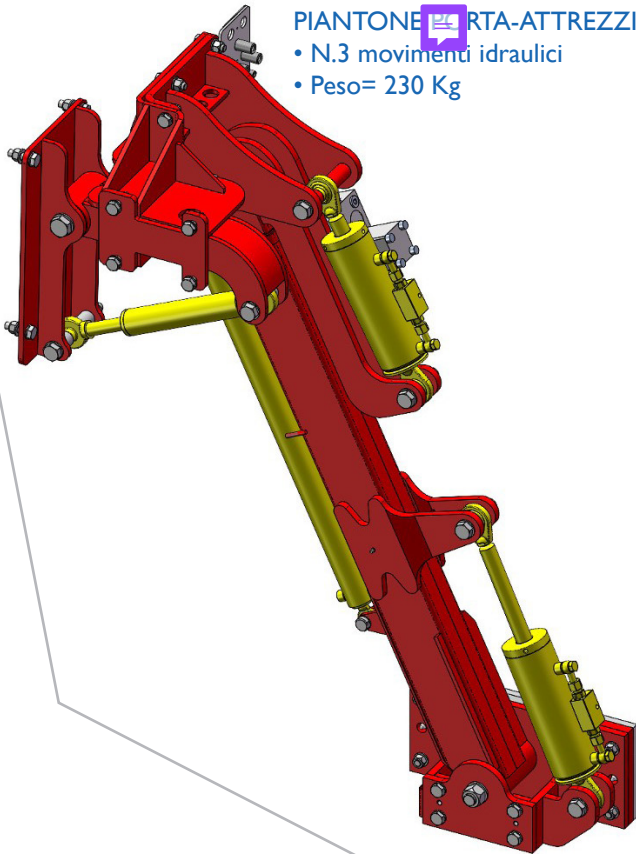

### CONTROLLI



JOYSTICK/  
CONSOLE  
LEVETTE ABBINATO  
A DISTRIBUTORE  
ELETTRICO



DISPLAY PER  
IMPOSTAZIONE E  
VISUALIZZAZIONE  
PARAMETRI

### ATTACCHI

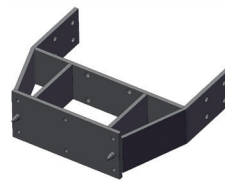

ATTACCO FISSO

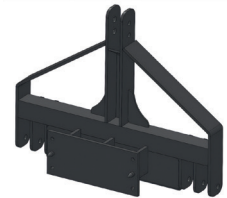

ATTACCO 3 PUNTI

### SERBATOIO



SERBATOIO  
40 LT.

### GRUPPO DI RAZZATRICE PER FIORI

## TF500A

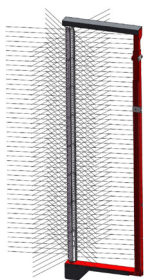

Il numero dei giri impostato da display viene mantenuto costante indipendentemente dal numero di giri del motore

ALBERCINGOLO

## DF500S

- Utilizzabile su ogni varietà
- Adatta anche ad impianti non cimati
- Alte prestazioni e consumi bassi
- Massima precisione con la minima aggressività



















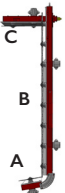



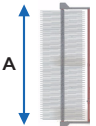

TESTATA DISCHI

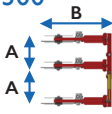
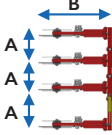

COMPRESSORE

### GRUPPO DEFOLLATRICE AD ARIA

### INFORMAZIONI TECNICHE / Technical Information / Información técnica

MODELLO Model Modelo				A	B	C		$\varnothing$ 				
	A	B	C									
<b>BF200</b> 	-	6	2	-	190	66	31	35	6-7	165	85	40
	-	7	2	-	221	66			6-7	175		
	-	8	2	-	252	66			6-7	185		
	-	9	2	-	283	66			6-7	195		
		6	2	35	190	66			6-7	185		
		7	2	35	221	66			6-7	195		
		8	2	35	252	66			6-7	205		
		9	2	35	283	66			6-7	215		
<b>MODELLO</b> Model Modelo	<b>A</b>		<b>B</b>									
	cm		cm		N°	Kg	HP	L/min				
<b>TF500A</b> 	220		-			75	85	30				
	250		-			80	85	30				
	280		-			85	85	30				
	310		-			90	85	30				
<b>MODELLO</b> Model Modelo		<b>A min</b>	<b>A max</b>	<b>B</b>	$\varnothing$ 							
	N°	cm	cm	cm	cm	Kg	HP	L/min				
<b>WF300</b> 	6 (3 bracci)	35	51	120	50	310	85	40				
<b>WF400</b> 	8 (4 bracci)	35	51	120	50	350	85	40				
<b>MODELLO</b> Model Modelo	<b>A</b>	<b>PRESSIONE</b> 		<b>IMPULSO</b> 								
	cm	bar		-		Kg	HP	L/min				
<b>DF 500S</b> <b>5 DUCCHI</b> 	240	0,4 - 0,9		300 - 800		160	85	25-30				