

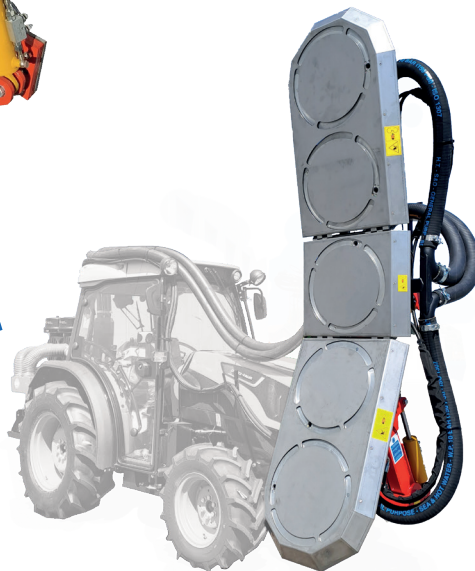

Sharp Innovators

PORTA-ATTREZZI
FRUTTETO

serie
FP850

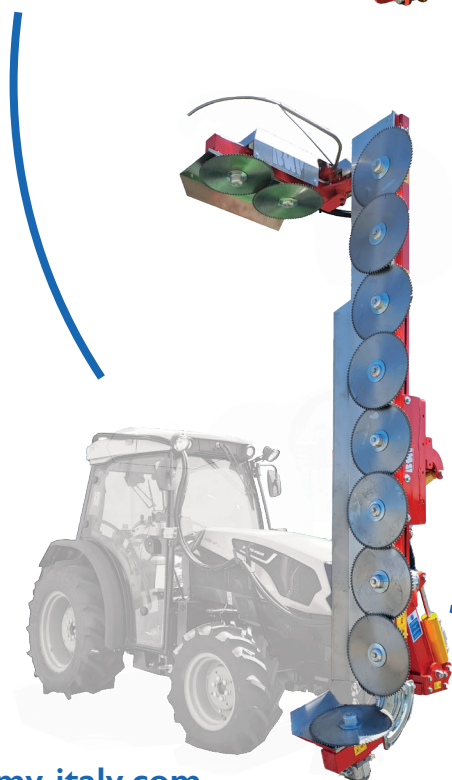
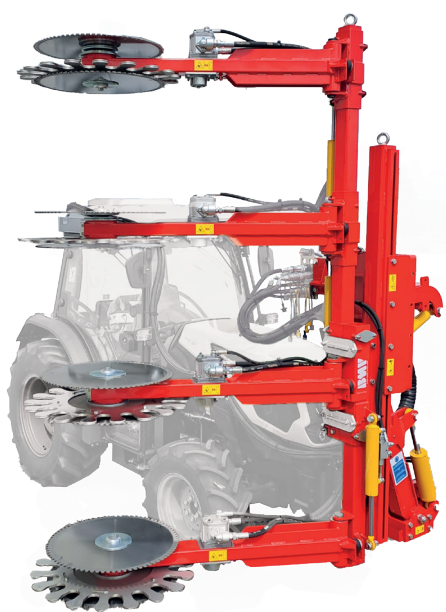

bmw-italy.com

BF200

1) **TASTATORE AUTOMATICO ELETTRONICO**
 abbinato a console joystick + display.
 Dal display è possibile regolare:

- FORZA MOLLA
- PISTONE TOP
- VELOCITA' RITORNO

2) **TASTATORE MECCANICO**
 a molla con pistone idraulico 0-90°

2) **TOP 0-90°**
 con pistone idraulico

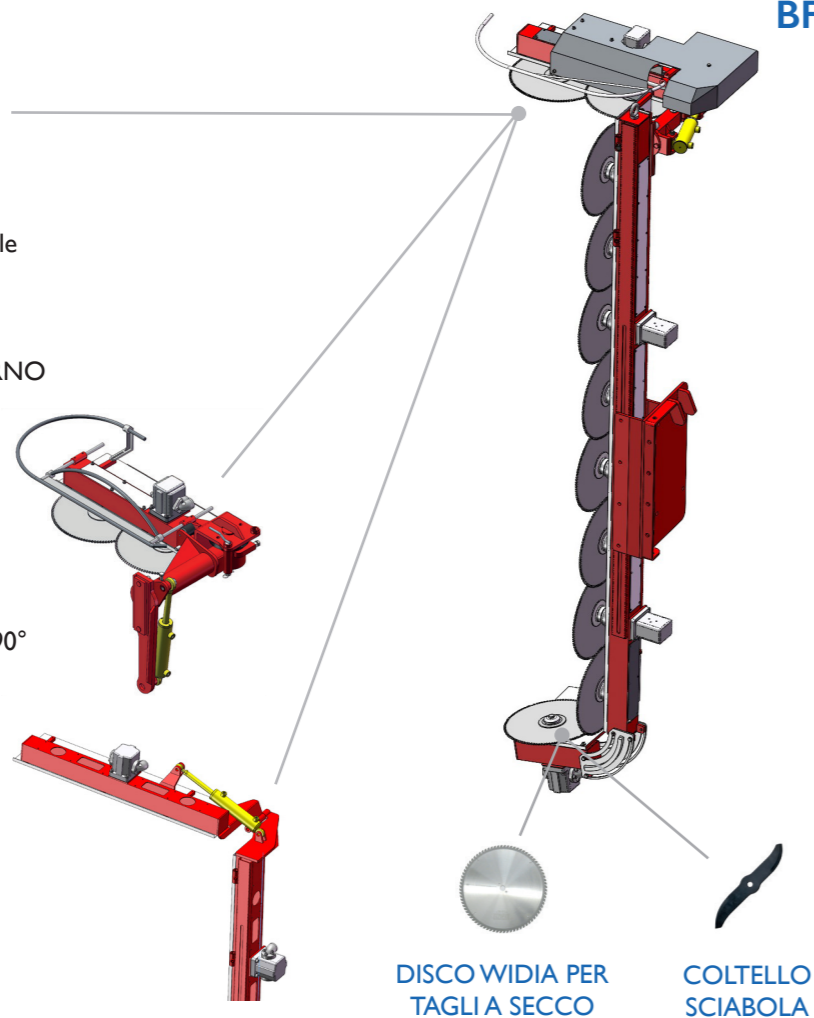

DISCO WIDIA PER TAGLIA SECCO

COLTELLO SCIABOLA

GRUPPO TAGLIO PER POTATURA (3 versioni di top disponibili)

FP850

PIANTONE PORTA-ATTREZZI:
 • N.3 movimenti idraulici
 • Peso= 230 Kg

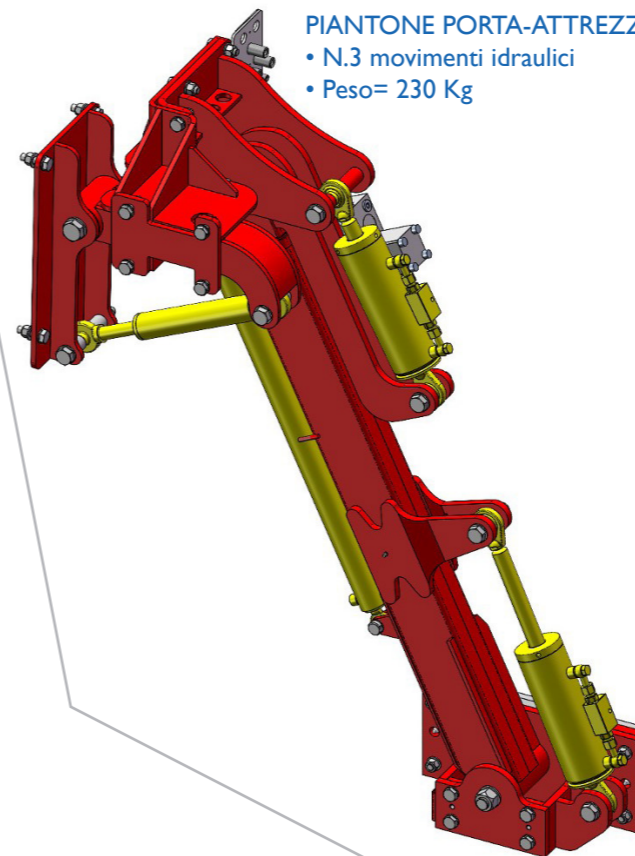

CONTROLLI



JOYSTICK/
 CONSOLE A 2
 LEVETTE ABBINATO
 A DISTRIBUTORE
 ELETTRICO



DISPLAY PER
 IMPOSTAZIONE E
 VISUALIZZAZIONE
 PARAMETRI

ATTACCHI



ATTACCO FISSO

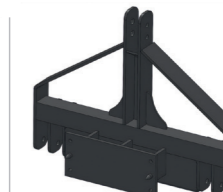

ATTACCO 3 PUNTI

SERBATOIO



SERBATOIO
 40 LT.

WF300

WF400

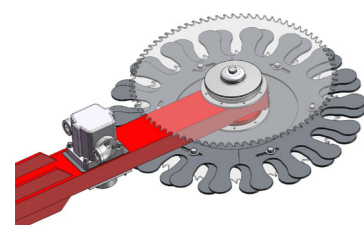

REGOLAZIONE DEL
 DIAMETRO DI TAGLIO IN
 BASE ALLA VEGETAZIONE

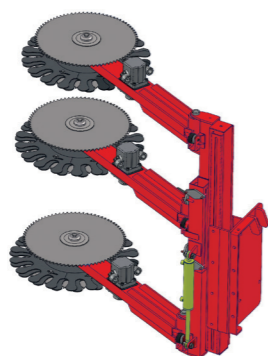

3 BRACCI

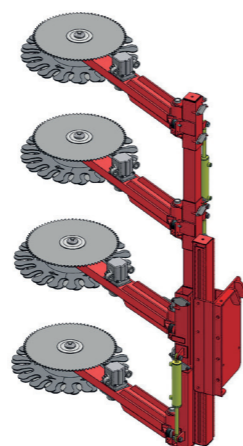

4 BRACCI

GRUPPO POTATRICE SELETTIVA A BRACCI

TF500A

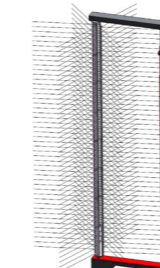

ALBERO SINGOLO

GRUPPO DI RADATRICE PER FIORI

Il numero
 dei giri impostato
 da display viene
 mantenuto costante
 indipendentemente
 dal numero di giri
 del motore

DF500S



TESTATA A 5 DISCHI

















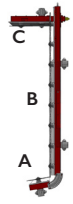



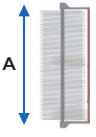



GRUPPO DEFOGLIATRICE AD ARIA

- Utilizzabile su ogni varietà
- Adatta anche ad impianti non cimati
- Alte prestazioni, consumi bassi
- Massima precisione con la minima aggressività

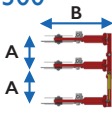
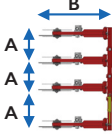

COMPRESSORE

INFORMAZIONI TECNICHE / Technical Information / Información técnica

MODELLO Model Modelo				A	B	C		\varnothing 						
	A	B	C										N°	cm
BF200 	-	6	2	-	190	66	31	35						
	-	7	2	-	221	66							6-7	165
	-	8	2	-	252	66							6-7	175
	-	9	2	-	283	66							6-7	185
		6	2	35	190	66							6-7	195
		7	2	35	221	66							6-7	185
		8	2	35	252	66							6-7	195
		9	2	35	283	66							6-7	205
MODELLO Model Modelo TF500A 	A													
	cm		N°		Kg		HP		L/min					
	220				75		85		30					
	250				80		85		30					
	280				85		85		30					
310				90		85		30						
MODELLO Model Modelo		A min	A max	B	\varnothing 									
	N°	cm	cm	cm	cm	Kg	HP	L/min						
WF300 	6 (3 bracci)	35	51	120	50	310	85	40						
WF400 	8 (4 bracci)	35	51	120	50	350	85	40						
MODELLO Model Modelo	A	PRESSIONE LAVORO	IMPULSI AL MINUTO											
	cm	bar	-		Kg	HP	L/min							
DF 500S 5 DISCHI 	240	0,4 – 0,9	300 - 800		160	85	25-30							